

A-A (1 : 5)

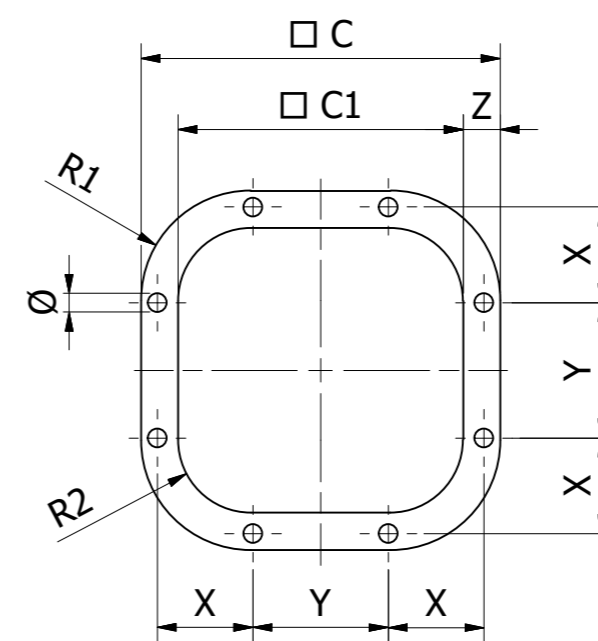

Schaal 1:10

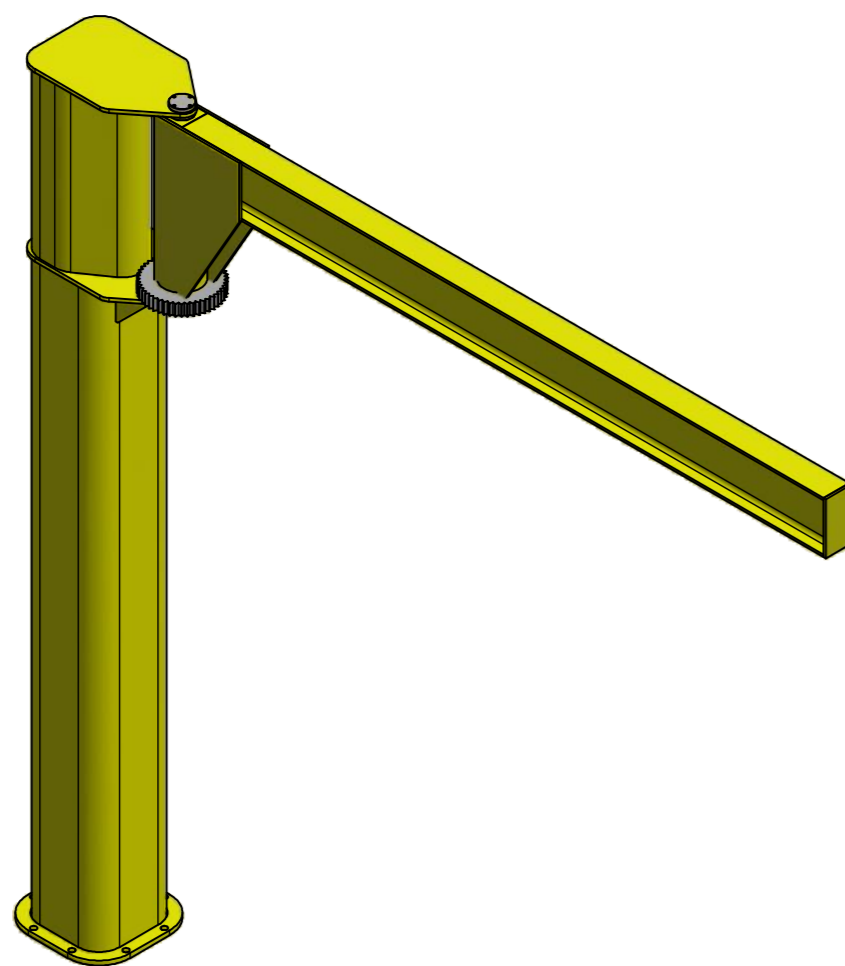
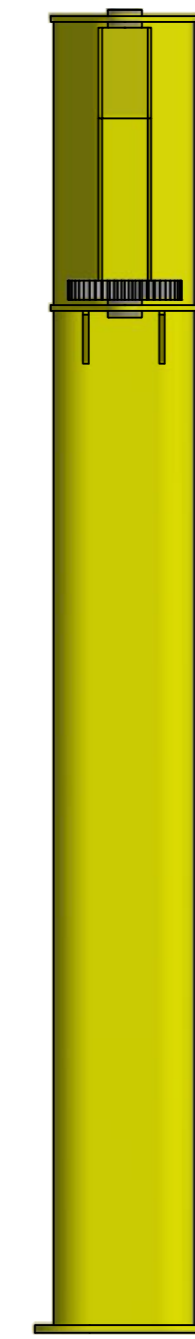
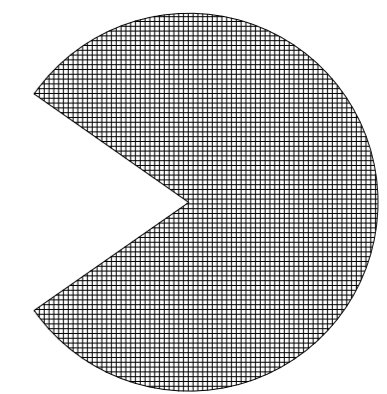

Bereik 290°

Indien niet anders aangegeven:	oleranflex vlg. ISO 2168-ak	Ruwheid ✓	Kanten breken 0.7mm bollet radius 0.8mm	Ruwheidsaanduiding vlg. NEN 3636	Passingen vlg. ISO 286-1 & 286-2	Vorm- en plaatstof vlg. NEN-ISO 1001	Lasaanduiding vlg. NEN 2356	Hydraulische en pneumatische symbolen vlg. NEN 3348
Engineer:	JB			laatste revisie:			Projectnummer:	
Datum:	12-1-2016			Datum:			Materiaal:	S235
Schaal:	1:20			Goedgekeurd:			Opmerking:	
Eenheid:	mm			Datum:				
Benaming:							Projectie:	Formaat:
Type T Kolom								A2
Breamark				Type T		Tekening nummer:	Revisie:	Order:
						Blad:	Van:	
						1	1	