

A-A ( 1 : 5 )

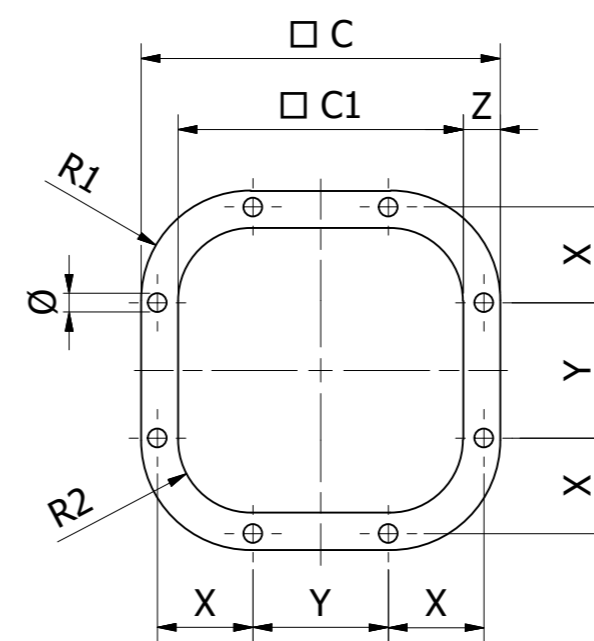

Schaal 1:10

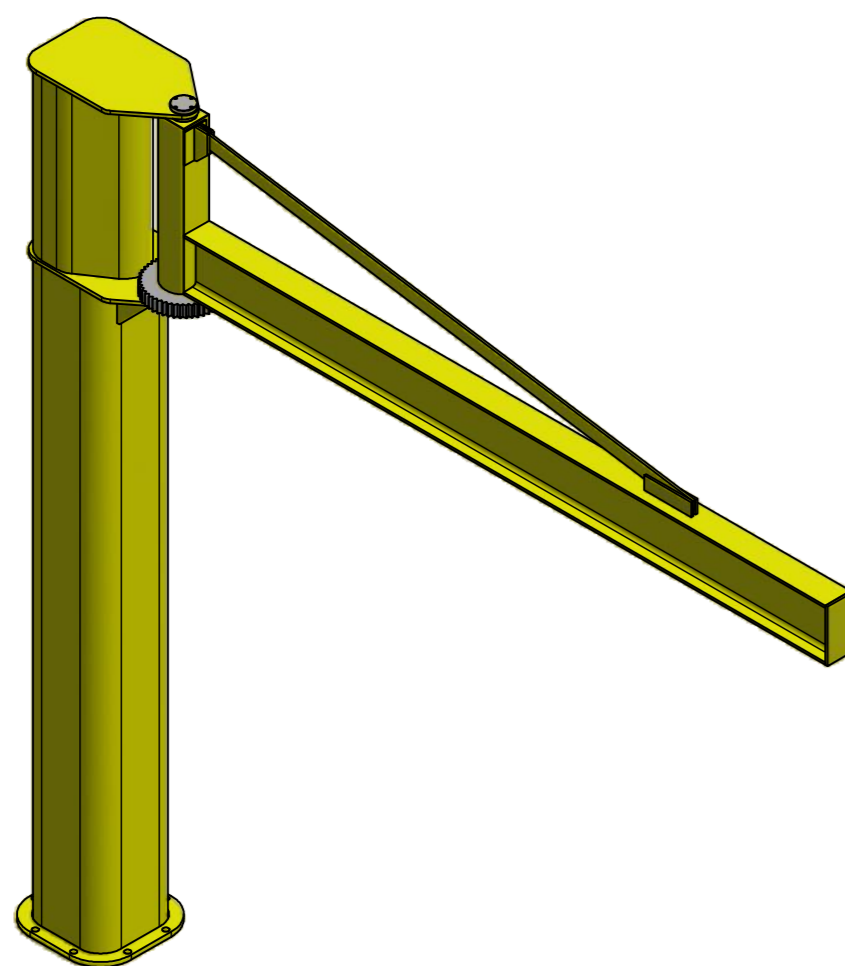
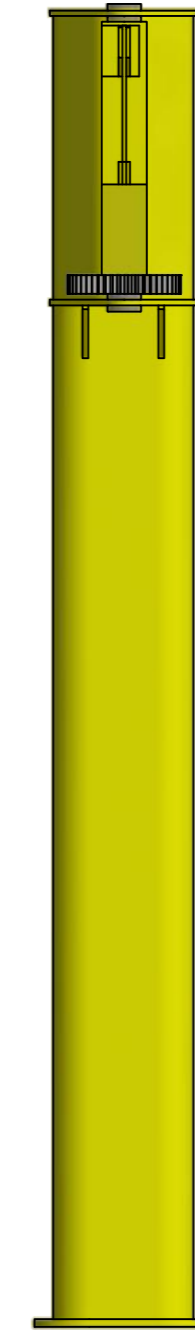
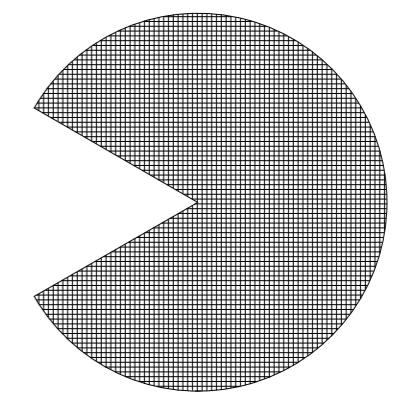

Bereik 300°

Indien niet anders aangegeven	oleranflex vigs ISO 2168-ak	Ruwheid ✓	Kanten breken 0.7mm bollet radius 0.8mm	Ruwheidsaanduiding vigs. NDK 363s	Fassingen vigs. ISO 286-1 & 286-2	Vorm- en plaatstof vigs. NDK-ISO 1001	Lasaanduiding vigs. NEN 2356	Hydraulische en pneumatische symbolen vigs. NEN 3348
Engineer :	JB			laatste revise :			Projectnummer :	
Datum :	12-1-2016			Datum :			Materiaal :	S235
Schaal :	1:20			Goedgekeurd :			Opmerking :	
Eenheid :	mm			Datum :				
Benaming :							Projectie :	Formaat :
Type H kolom								A2
<b>Breamark</b> Type H				Tekening nummer :	Revisie :	Order :		
				Blad :	Van :			
				1	1			